

SEPTIC TANK

1000 - Pumpout
Product No: TA10002

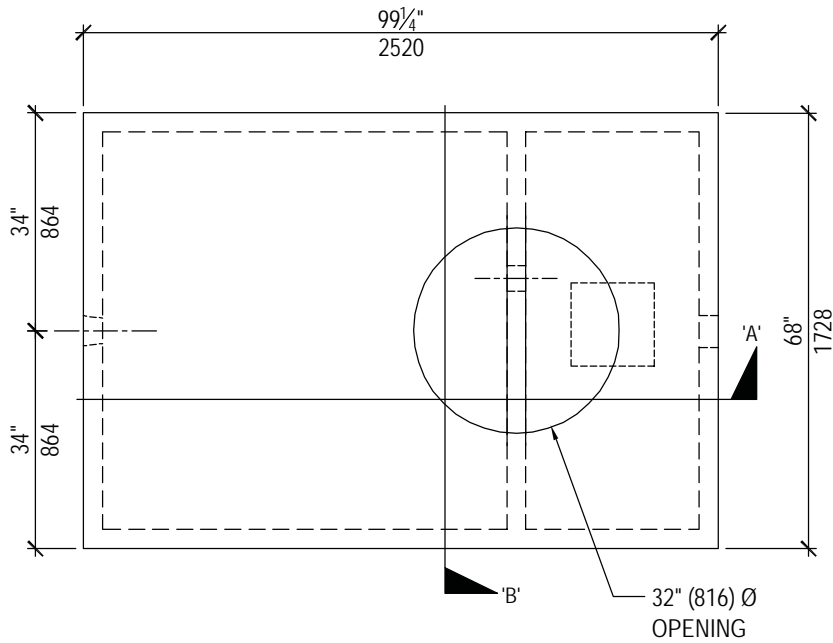

PLAN

TECHNICAL DATA

CSA Approved
Conforms with CSA Standard B66-05

Working Capacities	Septic Chamber	3503 liters (771 gallons)
	Effluent Chamber	1476 liters (325 gallons)
Concrete	35 MPa @ 28 days Sulphate Resistant	
Mass (thin lid)	5810 kg (12080 lbs.)	
Mass (thick lid)	6001 kg (13230 lbs.)	
Reinforcement	Deformed rebar and Welded Wire Mesh	
Max. Burial Depth To Top	1.8 meters (6'-0")	

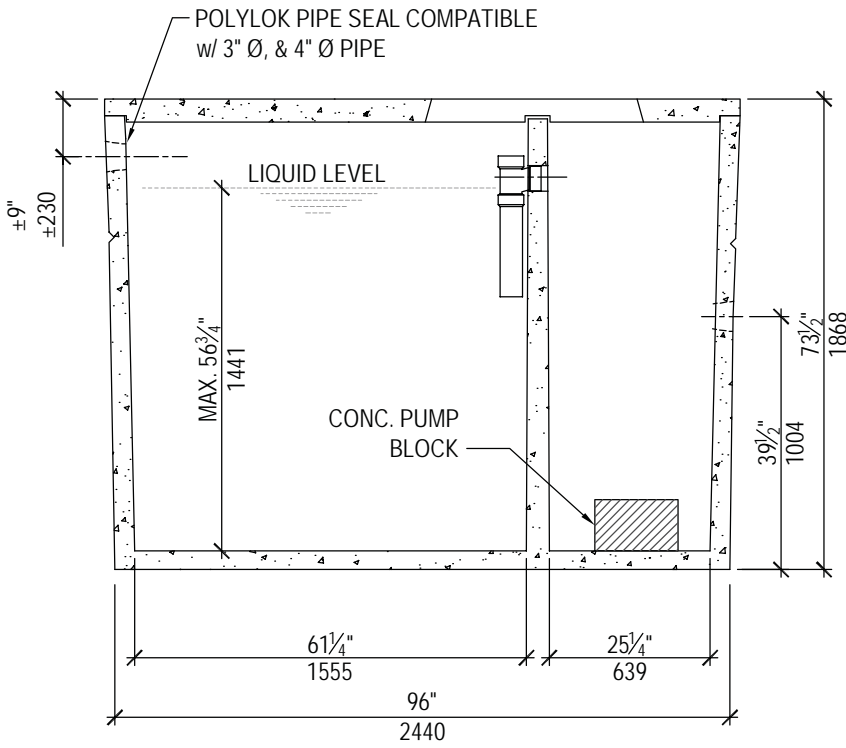

SECTION 'A'

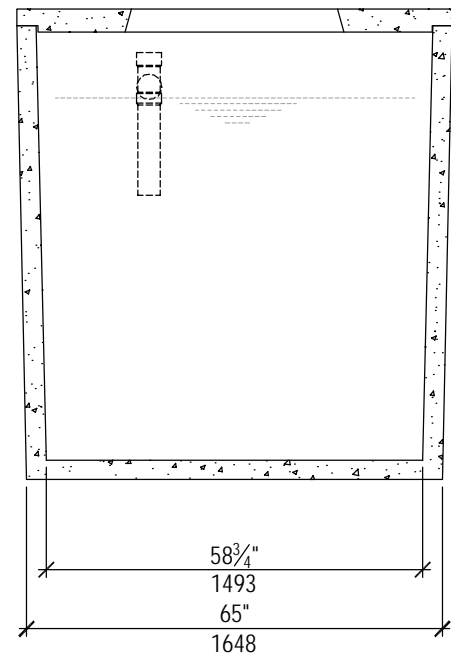

SECTION 'B'